



石家莊鐵道大學
SHIJIAZHUANG TIEDAO UNIVERSITY

网络精品课程

建筑工程制图

钢结构图

钢结构图概述

主讲：唐广

目录

- 概述
- 型钢的代号及标注
- 型钢的连接方法



概述

- 钢结构

由型钢连接而成的结构物，例如：钢梁、钢屋架、钢塔架、钢脚手架等。







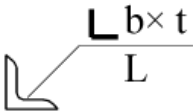
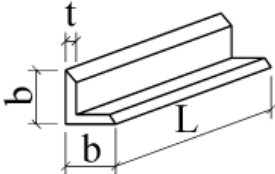

- 钢结构图

用来表示钢结构的图样。

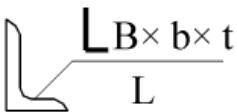
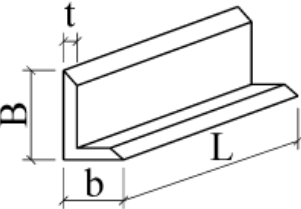
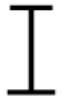
- 型钢

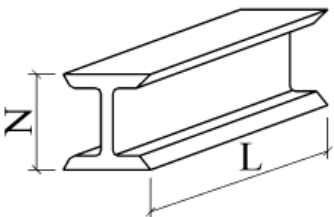
型钢是由钢厂按照标准规格轧制而成的钢材，其断面形状和尺寸是定型的，例如：角钢、工字钢、槽钢等。

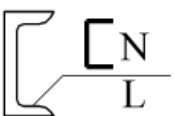
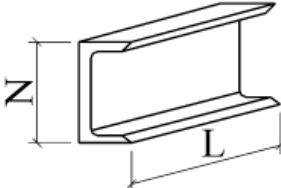
型钢的代号及标注

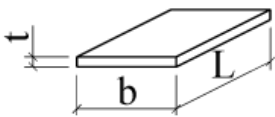
名称	代号	标注方法	立体图
等边角钢			
不等边角钢			
工字钢		 轻型工字钢加注Q字	
槽钢		 轻型槽钢加注Q字	
钢板			

钢结构中型钢的连接方法

- 焊接
- 铆接
- 螺栓连接



钢结构中型钢的连接方法

一、焊接









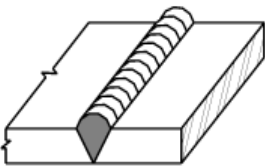

将被连接的型钢在连接部位加热使其和焊条熔化，凝结后成为不可分割的整体。

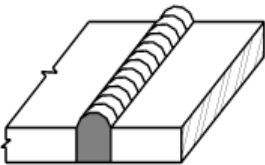
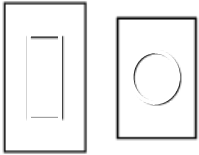
1. 焊缝类型及其符号

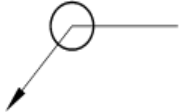
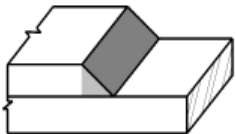
- 坡口焊缝
- 贴角焊缝
- 塞焊缝

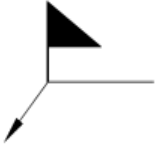
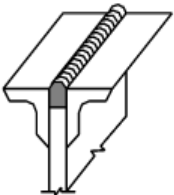
钢结构中型钢的连接方法

焊缝的图形符号和辅助符号

焊缝名称	焊缝形式	图形符号	符号名称	焊缝表示符号	辅助符号	标注方式
V形		∇	三面焊缝符号			
I形			周围焊缝符号			
贴角焊			现场焊缝符号			
塞焊			相同焊缝符号			

钢结构中型钢的连接方法

2. 焊缝的标注

- 在钢结构图中，必须把焊缝的**位置、形式、尺寸和辅助要求**标注清楚。

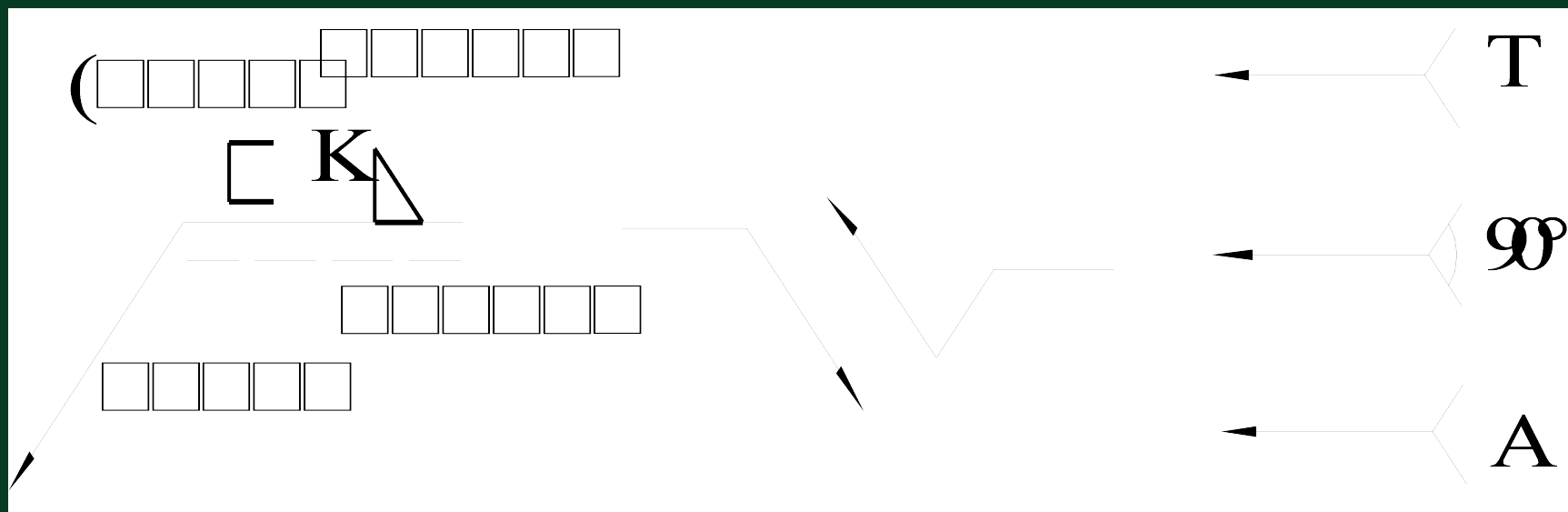

焊缝的标注方法

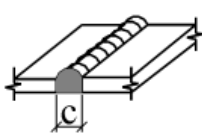
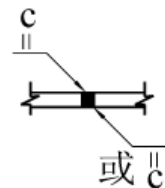
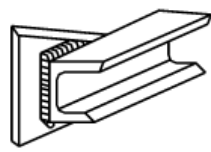
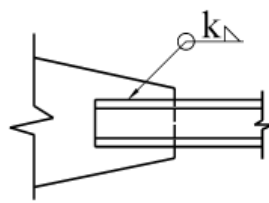
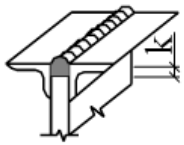
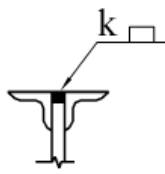
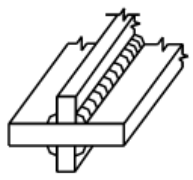
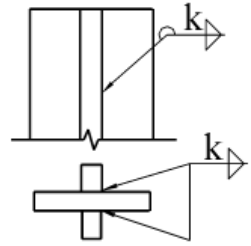
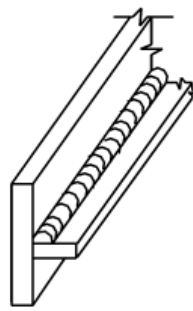
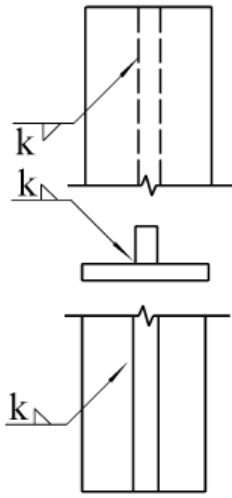
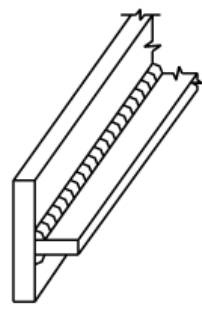
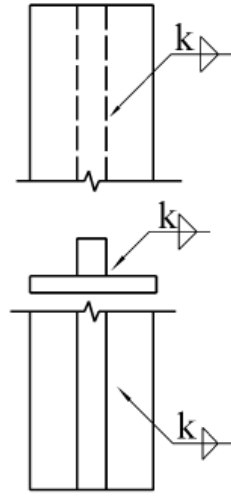
焊缝名称	焊缝形式	标注方法	焊缝名称	焊缝形式	标注方法
对接 I 型焊缝			周围贴角焊缝		
塞焊缝			3个焊件所组成的贴角焊缝		
T形接头贴角焊缝			T形接头双面贴角焊缝		

钢结构中型钢的连接方法

焊缝不连续时的画法及标注：

当焊缝分布不连续时，可见焊缝宜在焊缝处加**中实线**，不可见焊缝加**细栅线**。

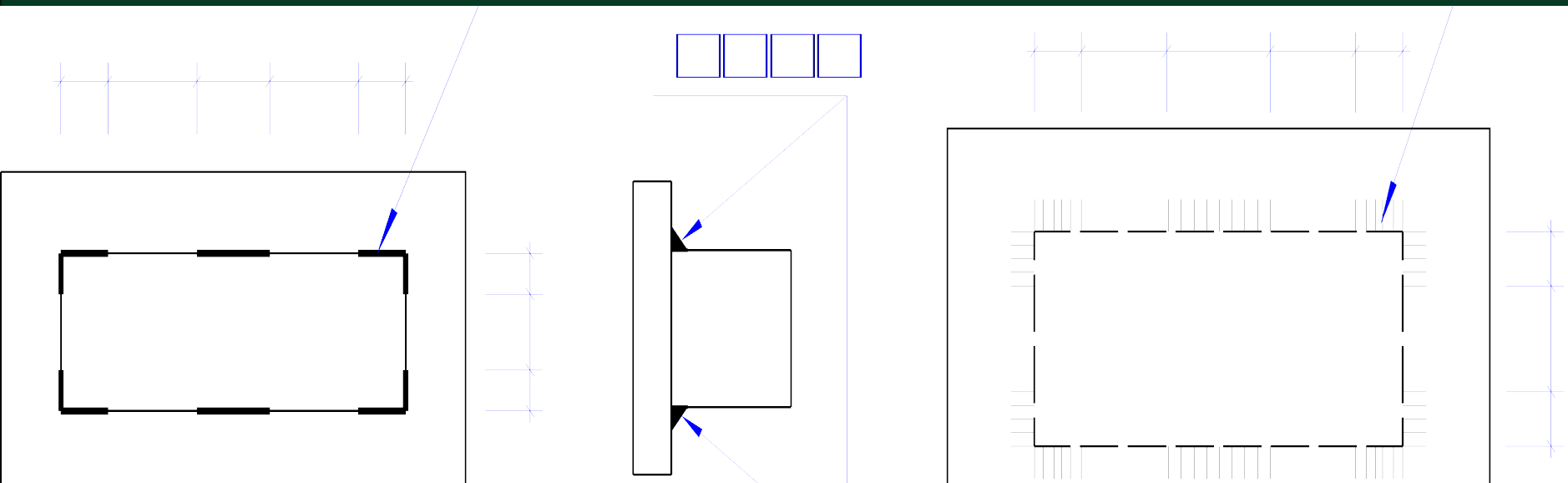

钢结构中型钢的连接方法

二、铆接

用铆钉将两块或两块以上的钢板连接在一起。

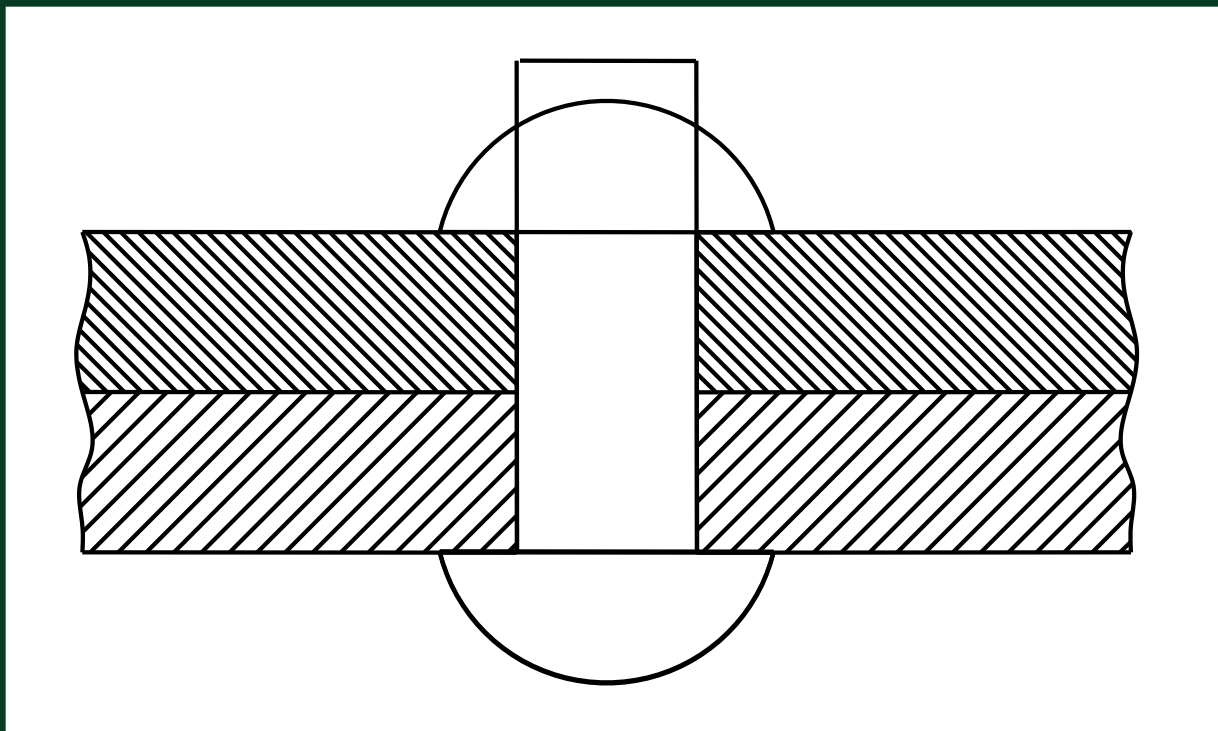

钢结构中型钢的连接方法

- 铆接分类
 - 工厂连接
 - 现场连接
- 铆钉类型

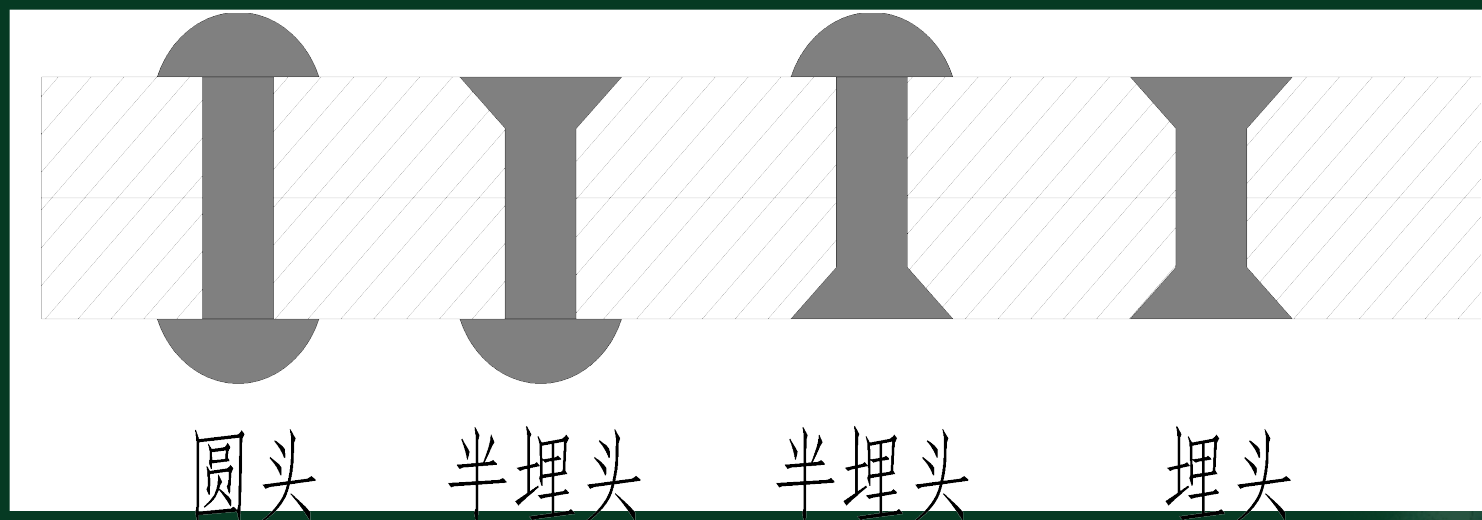







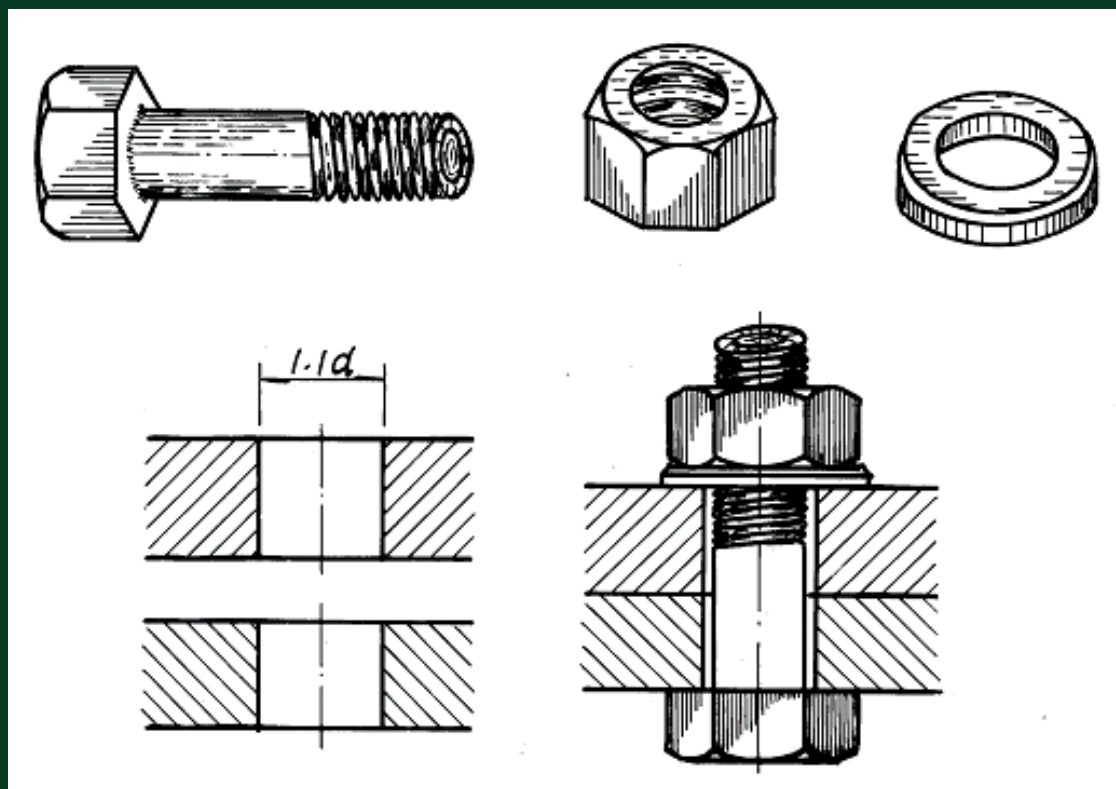



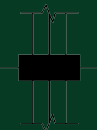

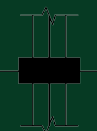
钢结构中型钢的连接方法

三、螺栓连接

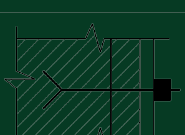
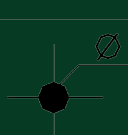
- 焊接和铆接都是不可拆卸的连接，螺栓连接是可拆卸的连接。
- 连接方法

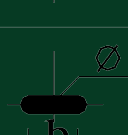

螺栓、孔、电焊铆钉图例

□ □	□ □	□ □	□ □
1	□ □ □ □		
2	□ □ □ □		
3	□ □ □ □		
4	□ □ □ □		
5	□ □ □ □ □		
6	□ □ □ □ □ □		
7	□ □ □ □		

1. □ “+” □ □ □ □ □ □ □ □

2. M □ □ □ □ □ □ □ □

3. Ø □ □ □ □ □ □ □ □

4. d □ □ □ □ □ □ □ □ □ □ □ □ □ □

□ □ □

5. □ □ □ □ □ □ □ □ □ □ □ □ □ □

□ □ □ □ □ □ □ □ □ □ □ □ □ □

□ □ □ □ □ □ □ □ □ □

小结

- 掌握型钢的代号及标注
- 掌握焊缝的标注方法

